

Switching signals generation technique for minimizing the RMS tracking error in active filters

F. Barrero¹, E. Romero¹, M^a I. Milanés¹ and J. M. Montero¹

¹ Department of Electronic and Electromechanical Engineering

E.U.I.I, Extremadura University

Apdo. 382, 06071 Badajoz (Spain)

phone +34 924 289600, fax +34 924 289601

e-mail: fbarrero@unex.es, eromero@unex.es, milanes@unex.es, josemont@unex.es

Abstract. In this paper a variation of the Pulse Width Modulation (PWM) operation technique, which we have called “of adjustable ramps”, is analysed. This technique will be applied to an active filter in order to compensate the low harmonics content present in a load current.

The aim is to prove that the proposed technique, whose objective is minimising the Root Mean Square (RMS) tracking error between the reference and the real currents, achieves a better performance than the usual PWM techniques in active filtering.

Simulation results comparing several generation techniques will be presented. These techniques will be analysed in terms of the total and individual harmonic distortion (THD and IHD_i) in the supply current.

Keywords

Switching signals generation techniques, PWM, active filter, harmonic distortion, RMS tracking error.

1. Introduction

The switching signals generation technique used for the switches of any electronic converter have influence in its capability for reaching the desire objectives.

The aim of this paper is to compare, on the same electronic system and control strategy, different conventional switching signal generation techniques with a new one that we have called “of adjustable ramps” or Adjustable PWM.

Figure 1 shows the electronic system chosen to accomplish this purpose. It corresponds to a three-phase neutral-point-clamped voltage-source inverter (VSI).

This generation strategies should guarantee that the supply currents follow, with the minor possible error (RMS), the reference current determined by the control strategy.

Synchronisation with the source voltage [1] is the selected strategy for the active filter control, that must achieve the two goals of maintaining a constant DC bus voltage and demanding a low harmonic distortion content currents with a displacement power factor near to the unity.

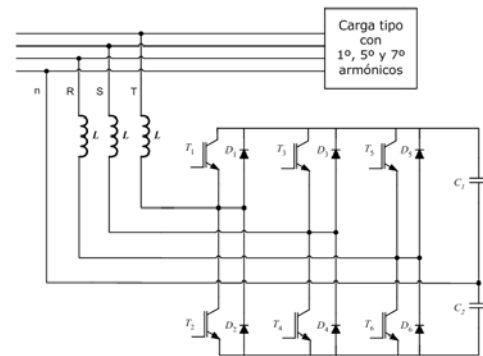

Fig. 1. Three-phase active filter topology

The references currents will be obtained by multiplying the source voltages by a factor. This factor will depend on the existing error between a reference DC voltage and the measured value.

In the present paper switching frequencies bellow 4 kHz will be used in order to employ ferromagnetic core inductors.

The scope of the present work is the fixed switching frequency PWM operation techniques. Its aim is to prove how the adjustable ramps PWM proposed in [2] could be the best option to operate an active filter in order to attenuate the low order harmonics demanded by the load.

2. PWM Operation techniques for control signals generation

Basic analysis of the operation techniques for inverter signal control generation could be follow in [2].

The PWM operation techniques studied in this work are Standard PWM, Symmetric PWM and Asymmetric PWM. These PWM techniques are represented in Figures 2 to 4.

We propose an Adjustable Ramps PWM that is represented in Figure 5. The aim of this technique is to minimise the RMS error between the referent and measured current by determining dynamically the most suitable ramp (crescent or decrescent) according to the present error sign.

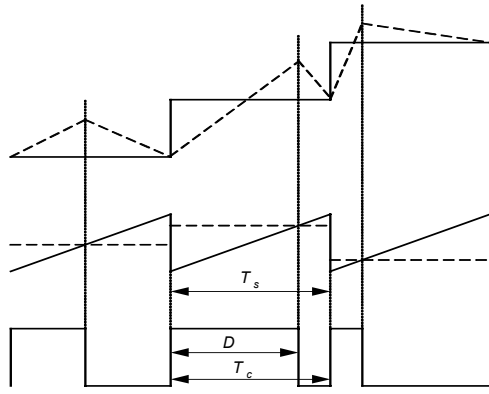

Fig. 2. Standard PWM technique

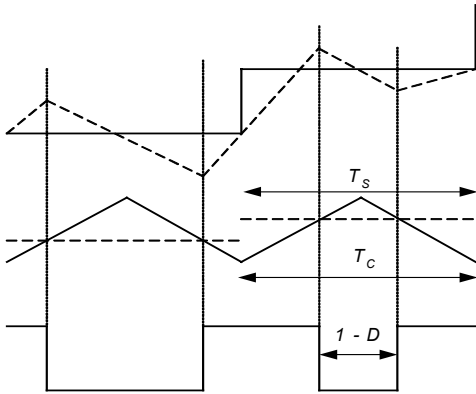

Fig. 3. Symmetric PWM technique

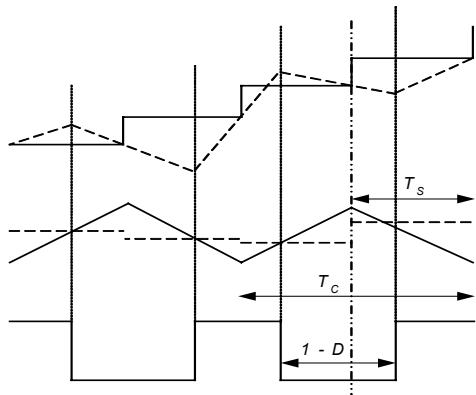

Fig. 4. Asymmetric PWM technique

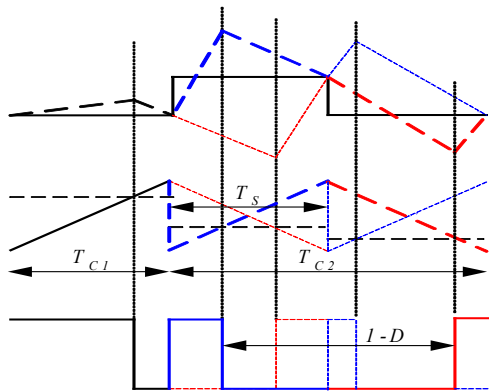

Fig. 5. Adjustable PWM technique

3. Simulation Results

The three-phase active filter must correct the pattern current that presents the 5th and 7th harmonics, in the way that in the corrected source current these harmonics have a lowest value. If it is possible, these values should be below the 4% of the fundamental harmonic value.

The value of the different parameters of the active filter (Figure 1) used for the simulation comparison appears on TABLE I. The pattern current used for this simulation is shown in Figure 6 and the corrected source current for the Adjustable PWM technique is shown in Figure 7.

TABLE I.- Simulation values

Parameter	Value
V_S RMS Source Voltage	220 V
$V_{dc} (= 2 V_C)$ DC Bus Voltage	1000 V
$V_C (= V_{C1} = -V_{C2})$ Capacitor Voltages	500 V
L Filter Inductances	70 mH
C_1, C_2 Filter Capacitors	3 mF

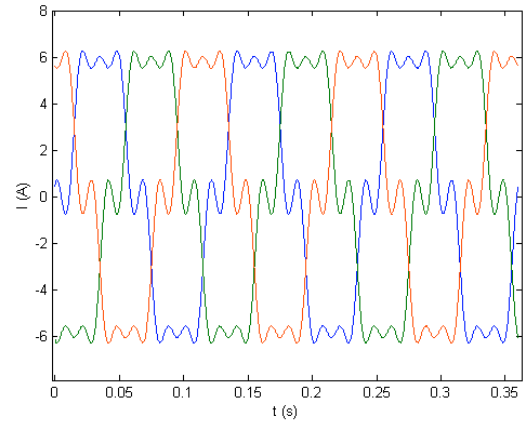

Fig. 6. Pattern Load Current

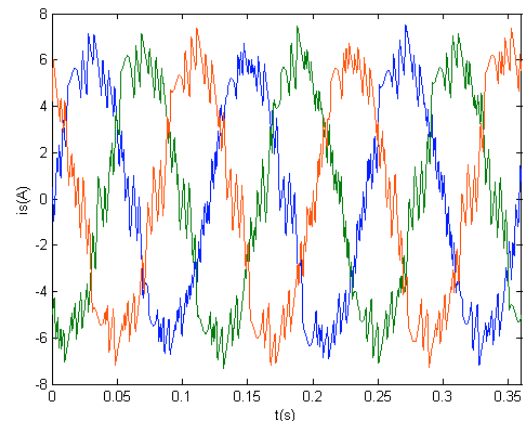

Fig. 7. Corrected Source Current with Adjustable PWM.

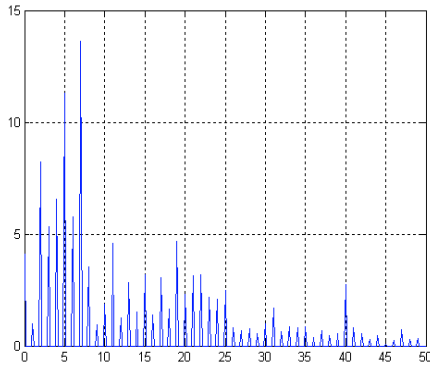

Fig.8. Standard PWM technique

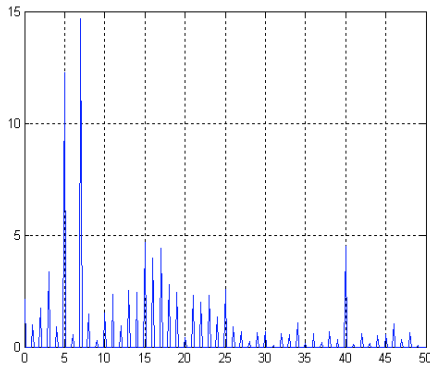

Fig. 9. Symmetric PWM technique

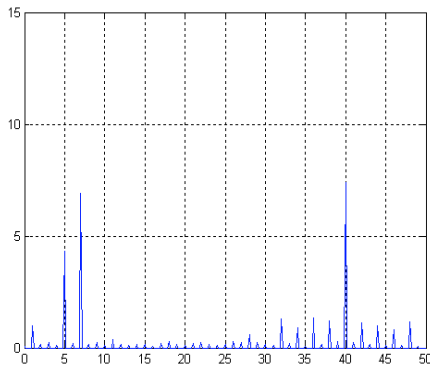

Fig. 10. Asymmetric PWM technique

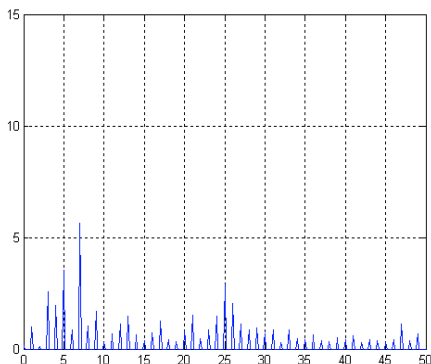

Fig. 11. Adjustable PWM technique

The principal distortion indexes of the corrected source current are shown in TABLE II, corresponding to each of the simulated PWM operation techniques.

TABLE II.- Principal distortion indexes of the corrected source current, corresponding to each of the simulated PWM operation technique.

Operation technique	DAT (%)	DA _{h,max} (%)	h _{max}	DA ₅ (%)	DA ₇ (%)
Pattern current	24,87	20,03	5	20,03	14,27
Standard PWM	30,39	13,64	7	11,28	13,64
Symmetric PWM	26,25	14,65	7	12,24	14,65
Asymmetric PWM	12,39	7,40	40	4,34	6,91
Adjustable PWM	15,53	5,63	7	3,54	5,63

The obtained current frequency spectrums depending on the operation technique are shown in Figures 8 to 11. Individual Harmonic Distortion Indexes, normalised as percent of the fundamental harmonic, are use in these figures.

Only asymmetric and adjustable ramps reduce the THD value of the proposed pattern current. However, the distortion index is high (up to 12%) because of the low switching frequency used for the inverter control.

THD is lowest in the case of Asymmetric PWM that does not produce significant harmonics between 8th and 27th (both of them includes). The most significant harmonics are located in high frequencies corresponding to the switching frequency and its multiples. This technique produces few harmonics located at prefixed frequencies (multiples of the switching frequency) but does not fulfil the primary objective of reducing the 5th and 7th harmonics.

Finally, the adjustable technique produce a worse THD than the asymmetric one, in an order of 2%. However, the attenuation of the 5th and 7th harmonics of the pattern current is much better, resulting that only the dominant 7th harmonic has an IHD greater than 4% (5,63%). This technique could be better in order to compliment the harmonics distortion normative.

4. Experimental Results

The proposed adjustable PWM technique has been compared with the Asymmetric PWM technique for the control of a mono-phase active filter with H-bridge inverter topology. This active filter corrects the current demanded by a rectifier connected to a resistor-inductor load.

The control strategy and control signals generation are implemented in a compatible PC equipped with a standard DAQ board. The system senses the source current and voltage and the DC bus voltage and uses two digital outputs as interface with the inverter switches drivers.

The values of the parameters used in the experimental system are shown in TABLE III.

TABLE III.- Experimental values

Parameter	Value
V_S RMS Source Voltage	230 V
$V_{dc} (= V_C)$ DC Bus Voltage	700 V
L Filter Inductance	70 mH
C Filter Capacitor	1,1 mF

The supply current demanded by the load before the active filter is on is shown in Figure 12, and the corrected source current is shown in Figures 13 and 14. In Figures 15 and 16 details of the gating signals are shown.

5. Conclusions

The proposed adjustable PWM [2] is a good operation technique for generating the gating control signals of an active filter in order to produce the best attenuation of the low order harmonics when the switching frequency is intentionally kept in low values (in this work below 4 kHz).

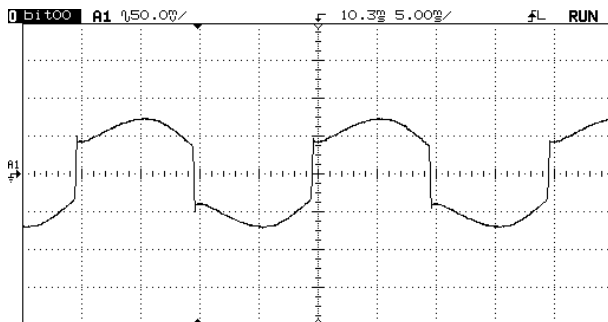

Fig. 12. Load current demanded by the rectifier

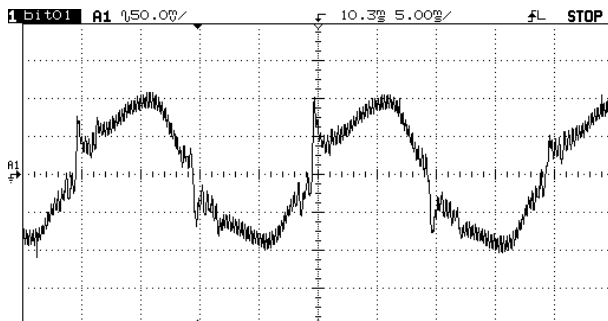

Fig. 13. Corrected source current with Asymmetric PWM

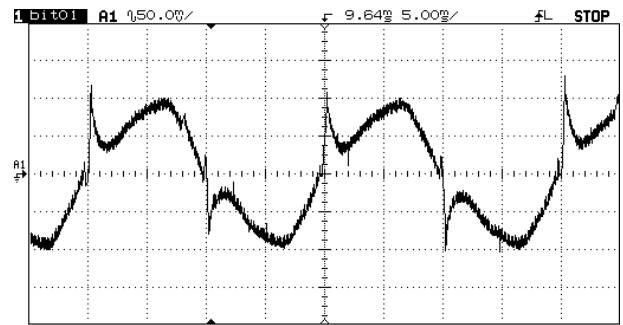

Fig. 14. Corrected source current with Adjustable PWM

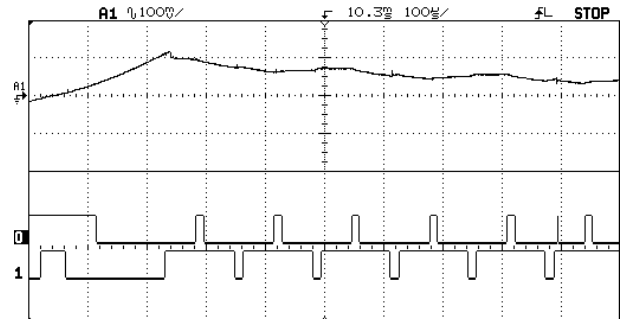

Fig. 15. Corrected source current and Control signals with Asymmetric PWM

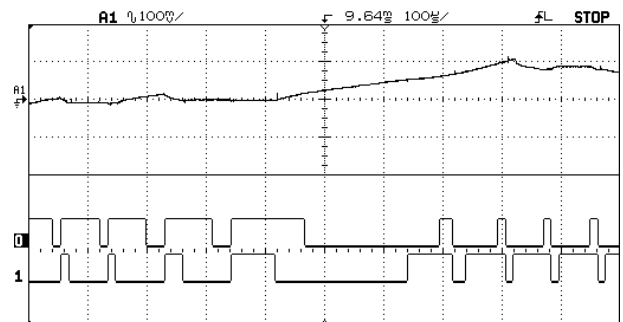

Fig. 16. Corrected source current and Control signals with Adjustable PWM

References

- [1] E. Romero, M. Milanés, F. Barrero. "Control de corrector de corriente mediante sincronización con tensión". Actas de la XI Reunión de grupos de investigación en Ingeniería Eléctrica. Badajoz 2001.
- [2] E. Romero, M. Milanés, F. Barrero, J.M. Montero. "Análisis de diferentes estrategias de generación PWM a baja frecuencia". Actas de la XII Reunión de grupos de investigación en Ingeniería Eléctrica. Córdoba 2002.
- [3] A. G. Pedder, A. D. Brown, J. N. Ross and A. C. Williams, "A Paralell-Connected Active Filter for the Reduction of Supply Current Distorsion", *IEEE Transactions on Industrial Electronics*, vol. 47, no. 5, 2000, pp. 1108-1117.
- [4] Fei Wang (2002) "Sine-Triangle versus Space-Vector Modulation for Three-Level PWM Voltage-Source Inverters", *IEEE Transactions on Industry Applications*, Vol. 38, N° 2, pp. 500-506.